

UNIFIX 100.1 WB

FR

EN

ES



Le support balcon

The pushpit mounting bracket

El soporte de fijación para balcón

Cher client, nous vous remercions pour votre achat de l'un de nos produits Uniteck. Veuillez lire avec attention toutes les instructions avant d'utiliser le produit.

DESCRIPTION

Le support Unifix 100.1 WB a été spécialement conçu pour fixer vos panneaux photovoltaïques Unisun 80.12M / 100.12M / 100.24M / 110.12BC sur votre bateau.

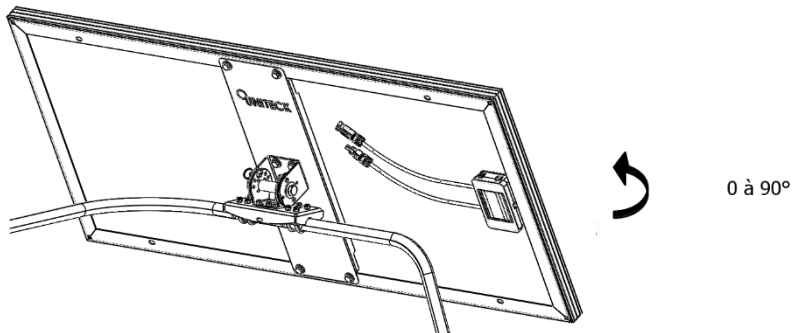



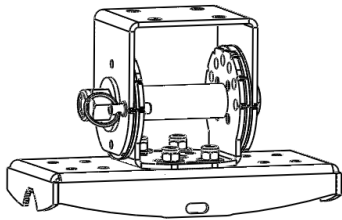

Il s'installe sur tous les balcons ou main courante en tube de diamètre 20 à 45 mm (longueur minimum du tube : 170 mm).

Grâce à sa structure et à la visserie en inox marine, il est parfaitement adapté pour un usage en milieu salin.

Dotés du système d'inclinaison multi-position, les supports Unifix vous permettent d'optimiser vos performances en fonction de l'orientation choisie.



Performance électrique en fonction de l'inclinaison et de l'orientation panneau

	0° 	30° 	60° 	90° 
Est	93%	90%	78%	55%
Sud-Est	93%	96%	88%	66%
Sud	93%	100%	91%	68%
Sud Ouest	93%	96%	88%	66%
Ouest	93%	90%	78%	55%

- Evitez les zones d'ombre ou que certains objets ne soient source d'ombre.
- Pour plus d'énergie, il est possible d'utiliser deux installations solaires :
 - panneaux avec même orientation : installation en parallèle (deux panneaux + un régulateur + un kit de câblage + connecteurs dérivation)
 - panneaux avec orientations opposées : deux installations séparées (un panneau + un régulateur + un kit de câblage) x2

UNIFIX 100.1 WB

PANNEAUX COMPATIBLES

Unfix 100.1 WB accepte 1 panneau avec 4 percages du cadre selon les entraxes suivants :

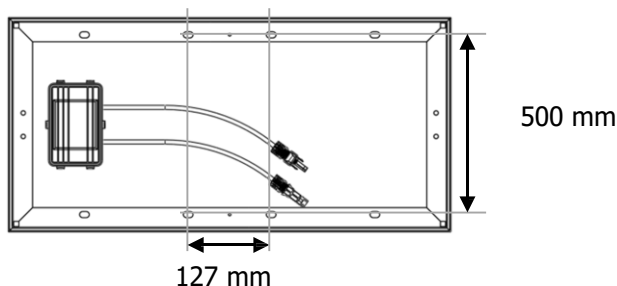

RECOMMANDATIONS

Montez les supports Unifix uniquement sur des surfaces présentant une portance suffisante. Tenez compte de la charge supplémentaire avec panneau :

Support	Panneau
Unifix 100.1 WB = 3,0 kg	Unisun 80.12M /100.12M /100.24M /110.12BC =6,3kg / 7,5kg / 7,5.kg/ 7,0 kg

Fixation : pour éviter que de grandes quantités de neige ne s'accumulent derrière le capteur, installez en amont des grilles d'arrêt appropriées.

La disposition des capteurs influence vos performances électriques. Choisissez l'inclinaison et l'orientation la plus optimale en fonction de votre environnement. Évitez les zones d'ombre ou que certains objets ne soient source d'ombre (ex. arbre)

Avant toute fixation et connexion, veuillez respecter :

- Les distances maximums indiquées ci-dessous entre chaque élément.
- L'ordre de raccordement

Instruction d'installation de l'Unifix cf p.12

CONSIGNES DE SÉCURITÉ

- Prenez les mesures appropriées pour prévenir les accidents pendant vos travaux de montage.
- Si le support et le matériel de montage sont exposés aux rayons du soleil pendant une longue période, il y a un risque de brûlure. Protégez-vous.
- A la fin des travaux, vérifiez que vos supports et panneaux soient bien fixés

GARANTIE

La garantie couvre tout défaut ou vice de fabrication pendant 1 an, à compter de la date d'achat (pièces et main d'œuvre).

La garantie ne couvre pas :

- l'usure normale des pièces
- les erreurs de montage

En cas de défauts, retournez le produit à votre distributeur, en y joignant :

- un justificatif d'achat daté (ticket de sortie de caisse, facture...)
- une note explicative du défaut.

Attention : notre SAV n'accepte pas les retours en port dû.

Après la garantie, notre SAV assure les réparations après acceptation d'un devis.

Contact SAV :

Uniteck- 1 Avenue de Rome

Zae Via Europa - bâtiment Cassis

34350 Vendres -France

France mail: sav@uniteck.fr

Fax: +33 (0)4 88 04 72 20

VOIR SUITE PAGE 12

Dear customer, thank you for purchasing one of our Uniteck products. Please read all the instructions carefully and thoroughly before using the product.

DESCRIPTION

The Unifix 100.1 WB mounting bracket is especially designed to fix your Unisun 80.12M / 100.12M / 100.24M / 110.12BC photovoltaic panel on your boat/yacht.

They can be installed on all balconies or handrails with tubes from 20 to 45 mm in diameter (minimum length of the tube : 170 mm).

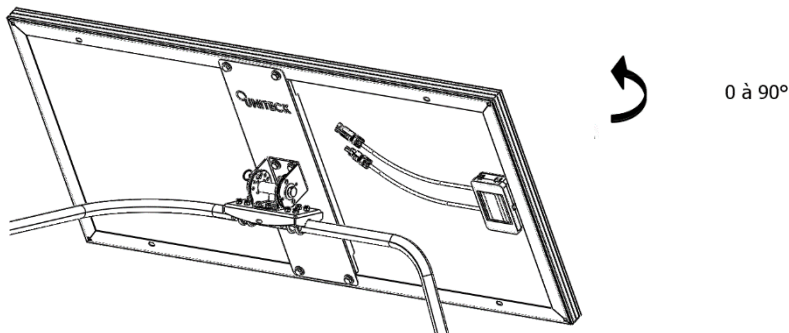

Thanks to their structure and marine stainless steel screws and bolts, they are perfectly suited for use in saline environments.

Equipped with a multi-position tilting system, Unifix brackets allow for an optimization of your panel's performance depending on the chosen orientation.

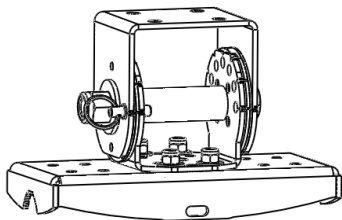

Electrical performance depending on tilt and panel orientation				
	0°	30°	60°	90°
East	93%	90%	78%	55%
South east	93%	96%	88%	66%
South	93%	100%	91%	68%
South west	93%	96%	88%	66%
West	93%	90%	78%	55%

- The arrangement of the sensors influences your electrical performance. Choose the optimum tilt and orientation according to your environment. Avoid shaded areas or objects that may cause shadows.
- For more energy, it is possible to use two solar systems:
 - panels with the same orientation: installation in parallel (two panels + one regulator + one wiring kit + branch connectors)
 - panels with opposite orientations: two separate installations (one panel + one controller + wiring kit) x2

UNIFIX 100.1 WB

PANEL COMPATABILITY

Unifix 100.1 WB can fix 1 panel with 4 holes in the frame at the spacing as below:

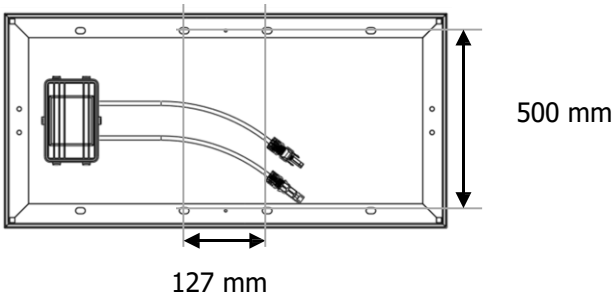

RECOMMENDATIONS

Mount Unifix brackets only on surfaces with sufficient bearing capacity. Consider the additional load with the panel:

Support	Panel
Unifix 100.1 WB = 3,0 kg	Unisun 80.12M /100.12M /100.24M /110.12BC =6,3kg / 7,5kg / 7,5.kg/ 7,0 kg

Fastening: to prevent large quantities of snow from accumulating behind the sensor, install appropriate barrier grids.

The position of the solar panel influences your electrical production. Choose the most optimal inclination and orientation to suit your environment. Avoid shaded areas or objects that are a source of shadow (eg tree)

Before attaching and connecting, please observe:

- the maximum distances between each element shown below.
- connecting order

For instructions for the installation of the bracket see page 12

SAFETY INSTRUCTIONS

- Take the appropriate measures to prevent accidents during your mounting steps.
- If the bracket and the mounting tools are exposed to sunlight for a long period, there is a risk of getting burnt. Make sure to protect yourself accordingly.
- When finished, check and ensure that all of your brackets and panels are fixed properly.

WARRANTY

The warranty covers any defect, manufacturing flaws for 1 year from the date of its purchase (Pieces and workforce).

Warranty does not cover:

- normal wear of parts
- faulty mounting of bracket

In case of failure, return the product to your distributor by attaching:

- the dated proof of purchase (receipt, bill...)
- explanatory note of the failure

Caution: Our after-sales service does not accept carriage forward/ collected returns.

After the warranty, our after-sales service ensures repairs after acceptance of a quotation.

After-sales service contact :

Uniteck- 1 Avenue de Rome

Zae Via Europa - bâtiment Cassis

34350 Vendres -France

E-mail : sav@uniteck.fr

Fax : +33 (0)4 88 04 72 20

See follow up on page 12

Estimado cliente, gracias por comprar nuestro producto Uniteck. Por favor lea con cuidado todas las instrucciones antes de usar el producto

DESCRIPTION

Los soportes Unifix 100.1 WB están concebidos especialmente para fijar sus paneles fotovoltaicos Unisun 80.12M / 100.12M / 100.24M / 110.12BC

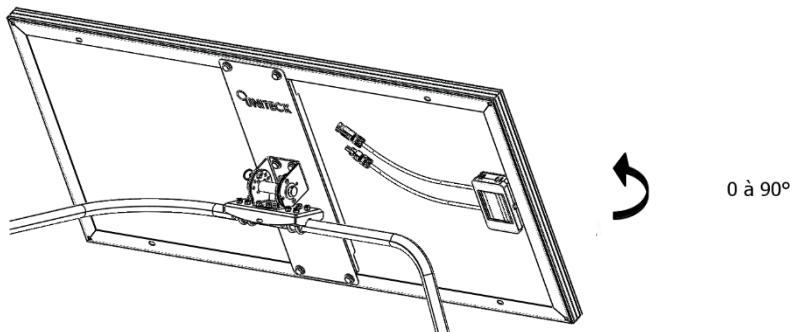

Se instalan sobre todos los balcones o pasamanos en tubos de diámetro entre 20 y 45 mm (longitud mínima del tubo: 130mm).

Gracias a sus estructuras y a sus tornillerías en Inox marino, están perfectamente adaptados para un uso en sitios salinos.

Orientable y abatible, el soporte Unifix permite aumentar su producción de energía de un 20% hasta un 50% con respecto a una instalación fija estándar

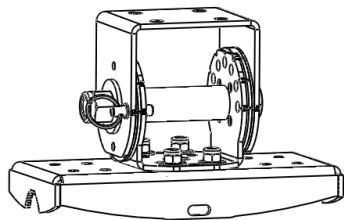

Rendimiento eléctrico en función de la inclinación y de la orientación del panel

	0°	30°	60°	90°
Este	93%	90%	78%	55%
Sur-Este	93%	96%	88%	66%
Sue	93%	100%	91%	68%
Sueoeste	93%	96%	88%	66%
Oeste	93%	90%	78%	55%

- Evite las zonas de sombra o que algunos objetos sean origen de sombra
- Para más energía, es posible usar 2 instalaciones solares :
 - paneles con la misma orientación : instalación en paralelo (dos paneles + un regulador + un kit de cableado + conectores derivación)
 - paneles con orientaciones opuestas : dos instalaciones separadas (un panel + un regulador + un kit de cableado) x2

UNIFIX 100.1 WB

PANELES COMPATIBLES

Unfix 100.1 WB acepta 1 panel con 4 agujeros de marco en las siguientes distancias

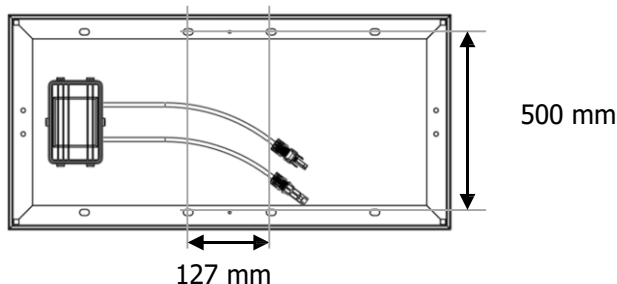

RECOMENDACIONES

Monte los soportes Unifix sólo en superficies que son capaz de aceptar el peso suficiente. Tome en cuenta el peso adicional con el panel:

Soporte	Panel
Unifix 100.1 WB = 3,0 kg	Unisun 80.12M /100.12M /100.24M /110.12BC =6,3kg / 7,5kg / 7,5.kg/ 7,0 kg

Montaje: Para evitar que se acumule una gran cantidad de nieve detrás del sensor, instale las rejillas de detención adecuadas aguas arriba.

La disposición de los sensores influye en su rendimiento eléctrico. Elija la inclinación y orientación más óptimas según su entorno. Evite las áreas sombreadas o los objetos que no dan sombra (por ejemplo, los árboles).

Antes de montar y conectar, tenga en cuenta lo siguiente:

- Las distancias máximas indicadas a continuación entre cada elemento.
- El orden de conexión

Instrucciones de instalación de Unifix véase pág.12

CONSIGNAS DE SEGURIDAD

- Tome las medidas apropiadas para prevenir los accidentes durante sus trabajos de montaje.
- Si el soporte y equipamiento de montaje están expuestos a los rayos del sol durante una larga duración, hay un riesgo de quemadura. Protéjase.
- En fin de los trabajos, verifique que sus soportes y paneles están bien fijados.

GARANTÍA

La garantía cubra todo defecto o todo vicio de fabricación durante 1 año, a partir de la fecha de compra (piezas y mano de obra)

La garantía no cubre :

-el desgaste normal de las piezas

En caso de avería, devuelva el aparato a su distribuidor, con :

- un justificado de compra con fecha (tiquete de caja central, factura, ...)

- una nota explicativa de la avería

Cuidado : nuestro Servicio Postventa no acepta devoluciones a portes debidos.

Después la garantía, nuestro Servicio Postventa asegura las reparaciones después aceptación de un presupuesto.

Contacto SAV :

Uniteck- 1 Avenue de Rome

Zae Via Europa - bâtiment Cassis

34350 Vendres -France

France mail: sav@uniteck.fr

Fax: +33 (0)4 88 04 72 20

INSTALLATION - FIXATION

FR Liste des pièces

EN Provided elements

ES Lista de las piezas

							
M8x20 X8	D8 X8	M8 X8	M6x16 X4	D6 X4	M6 X12	D8x15 X4	M6x53x34x25 X4

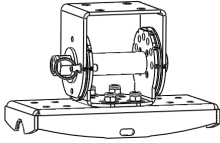
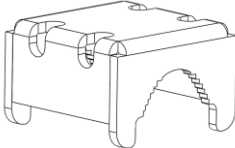
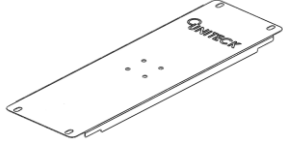
		
N°1 X1	N°2 X2	N°3 X1

Fr

Couple de serrage préconisé

Vis	Couple
M5	5,10 Nm
M 6	8,80 Nm
M 8	21,50 Nm
M 10	44,00 Nm

Nb. Coefficient de frottement moyen $\mu=0,20$ / Serrage à 50% de la limite élastique

En

Recommended Tightening torque

Screw	Torque
M5	5,10 Nm
M 6	8,80 Nm
M 8	21,50 Nm
M 10	44,00 Nm

Nb. Average friction coefficient $\mu=0,20$ / Tightening at 50% of the elastic limit.

Es

Par de apriete preconizado

Tornillo	Par
M5	5,10 Nm
M 6	8,80 Nm
M 8	21,50 Nm
M 10	44,00 Nm

Nb. Coeficiente de fricción medio $\mu=0,20$ / Presión al 50% de la límite elástica

INSTALLATION - FIXATION

Fr



Fixez la base de rotation sur votre balcon ou main courante (tube de diamètre 20 à 45mm).

En

Fix the base on the pushpit or on the handrail (tube diameter from 20 to 45 mm).

Es

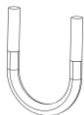
Fije la base de rotación sobre su balcón o su pasamano (tubo con diámetro entre 20 y 45mm).

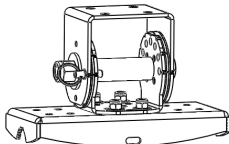
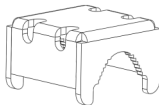
	X4
	M6 X8
	N°1 X1
	N°2 X1

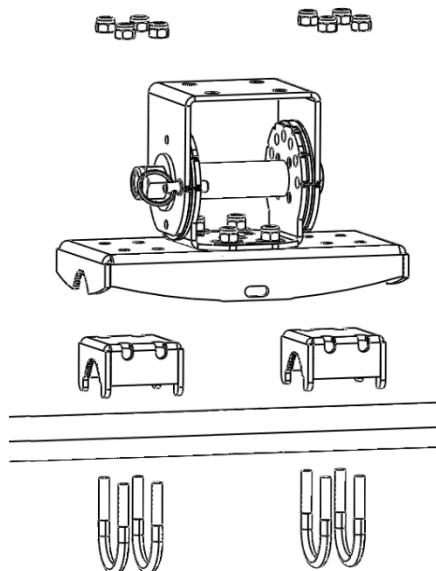

Fr Les pièces N°2 sont amovibles et glissantes.
Lors du montage, prendre une grande précaution pour éviter les chutes par-dessus bord.



En The items N°2 are sliding and removable pieces.
While mounting, take all the appropriate measures to avoid the pieces fall overboard



Es Piezas N°2 son desmontables y resbaladizas
Durante la instalación, tener mucho cuidado para evitar caídas al mar.

INSTALLATION - FIXATION

Fr



Fixez la platine N°2 sur la base de rotation N°1.

En

Fix the item N°2 on the bracket N°1.

Es

Fije la pieza N°2 sobre la base de rotación N°1.

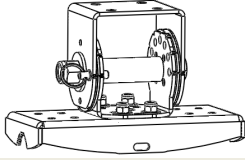
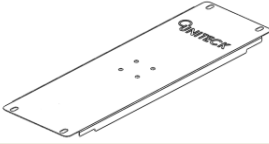
	M8x16 X4
	D8 X4
	M8 X4
	N°1 X1
	N°3 X1

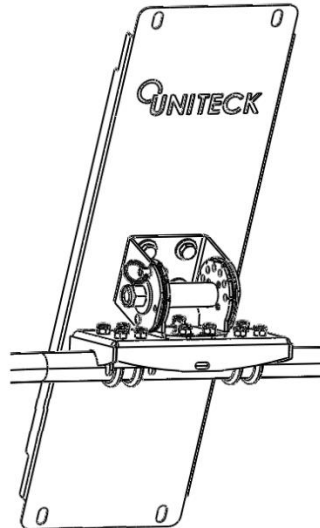
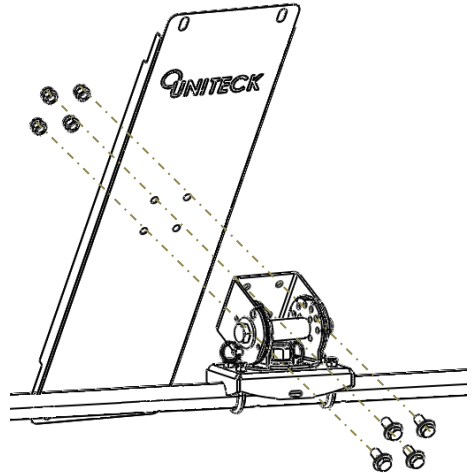

INSTALLATION - FIXATION

Fr

Fixer le votre panneau solaire.

Afin d'éviter le phénomène de Corrosion Galvanique, positionnez la pièce isolante entre le cadre du panneau solaire en aluminium anodisé et le support en Inox.

En

Fix your solar panel.

To avoid the phenomenon of galvanic corrosion, position the isolating pieces between the frame of the solar panel of anodized aluminium and the stainless steel bracket

Es

Fije el soporte sobre su panel solar.

Para evitar el fenómeno de corrosión galvánica, coloque la pieza aislante entre el cuadro del panel solar en aluminio anodizado y el soporte en Inox.

	M8x16 X4
	D8 X4
	M8 X4
	D8 X4

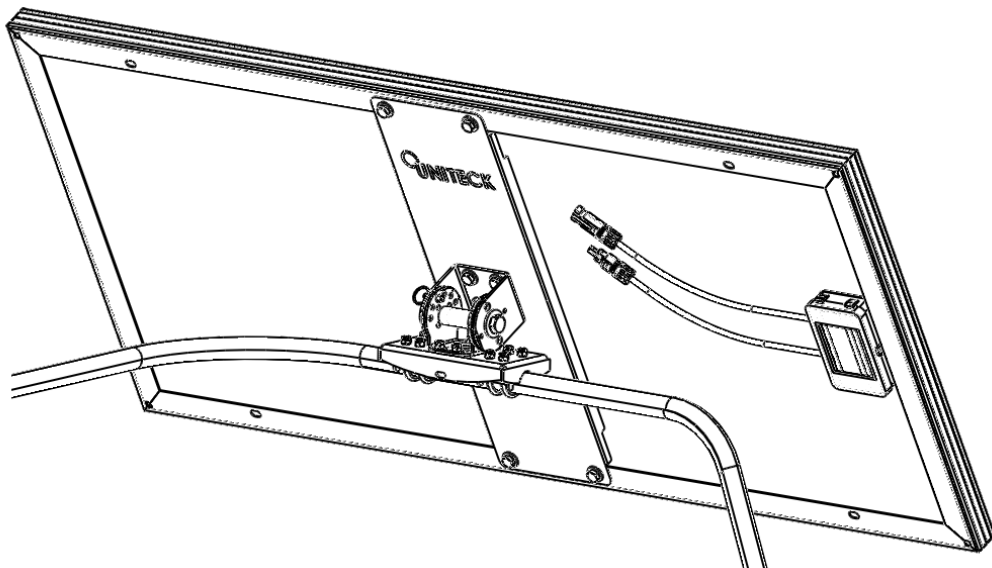
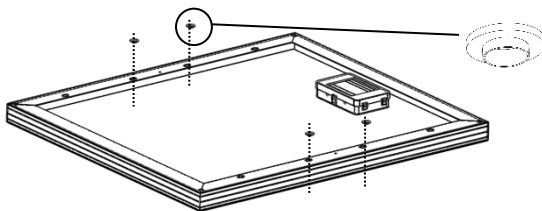

INSTALLATION - FIXATION

Fr

Une fois l'orientation choisie, positionnez la goupille à bille pour bloquer la rotation de l'Unifix.

En

When you have chosen the inclination, position the locking pin to block the rotation of the Unifix.

Es

Una vez la orientación elegida, posicionar el perno para bloquear la rotación del Unifix

