

brilliance in solar lighting

photinus



GERMAN
DESIGN
AWARD
SPECIAL
2019

INSTALLATIONSANLEITUNG INSTALLATION INSTRUCTION

V.1 | 2021

juno plus

juno plus

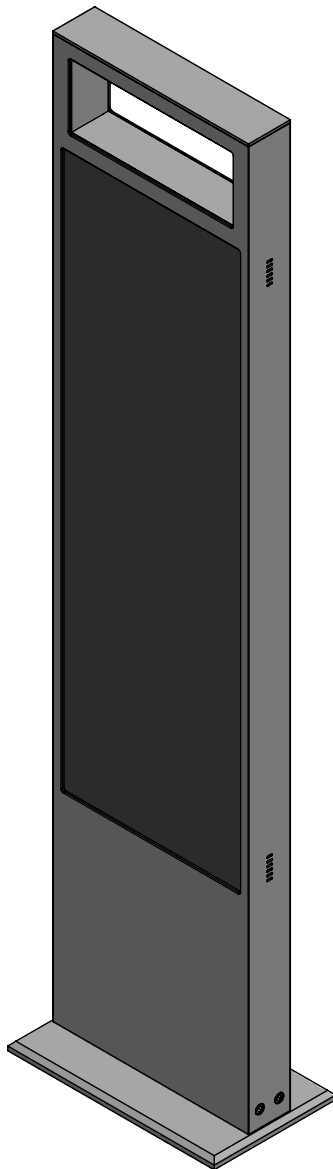

LIEFERUMFANG / INCLUDED PARTS

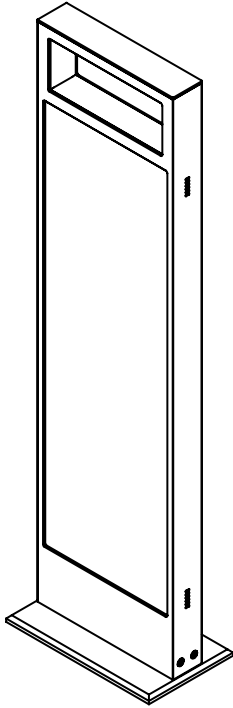

1x

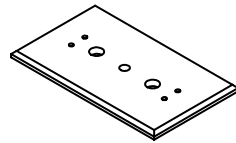

1x



2x



A-4x

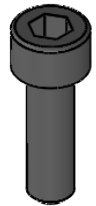

B-4x

BENÖTIGTES WERKZEUG IHRERSEITS / TOOLS REQUIRED

1 Inbusschlüssel / Allen Wrench 4

AKKU UND LICHTMAST / BATTERY AND POLE

1

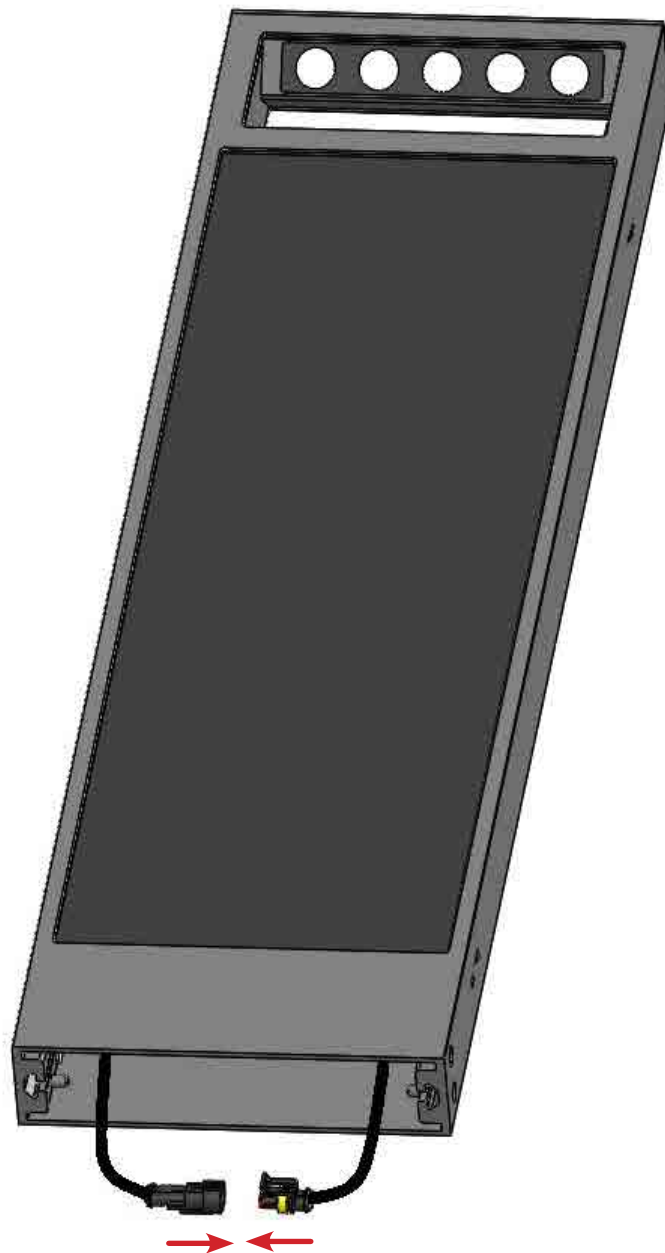

PHOTOVOLTAIK MODUL / PHOTOVOLTAIC MODULE

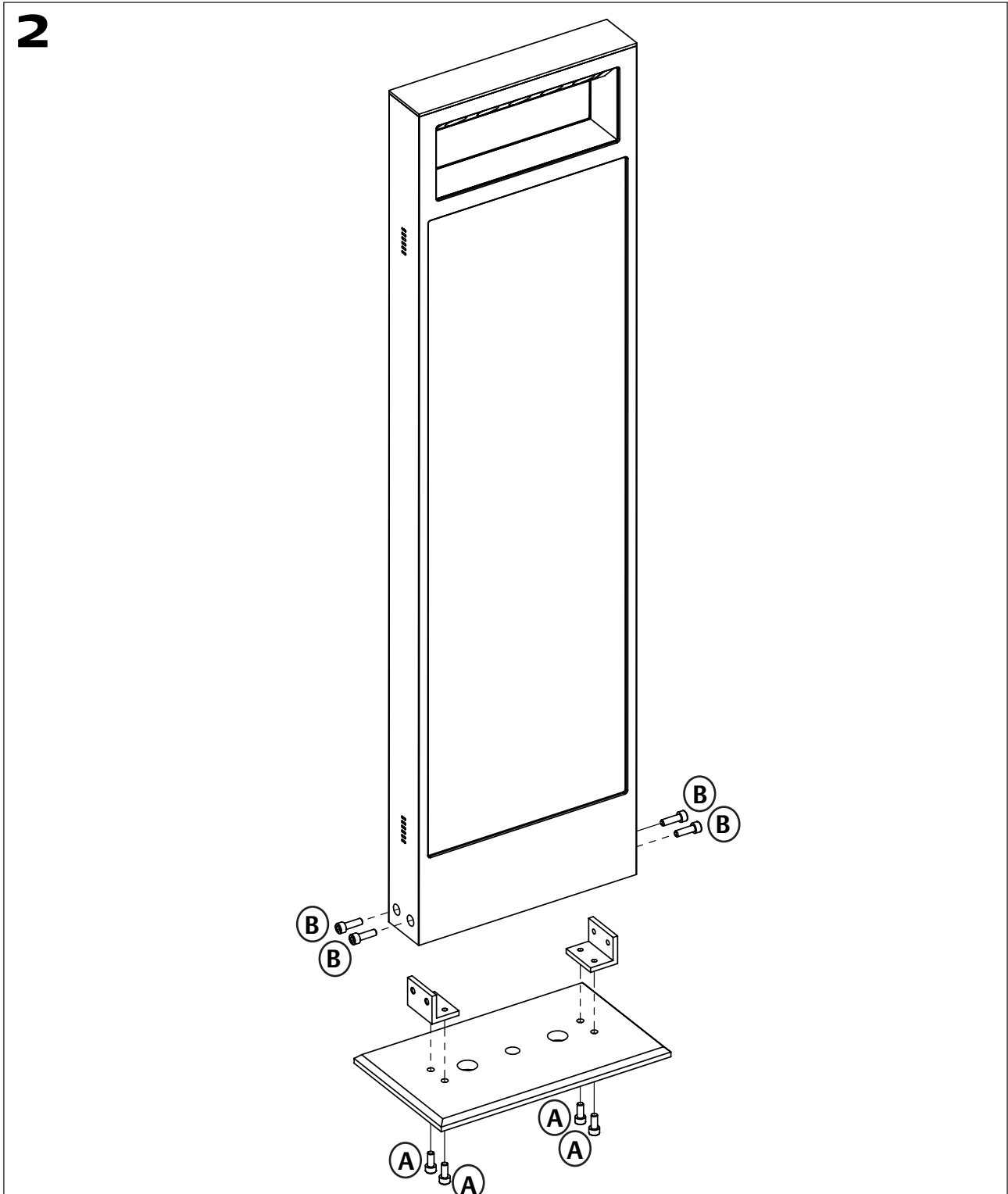

MONTAGEMÖGLICHKEIT 1 - BETONFUNDAMENT

MOUNTING POSSIBILITY 1 - CONCRETE FOUNDATION

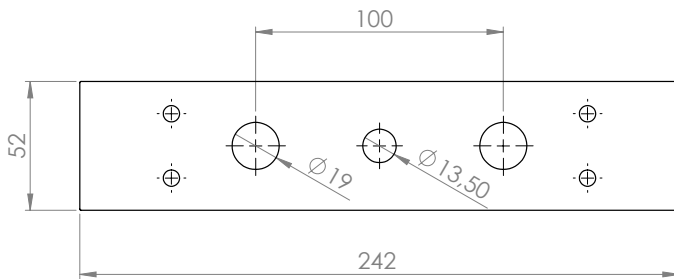
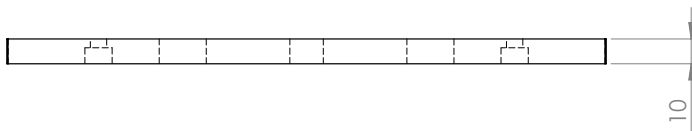

Befestigung mit
 kleiner Bodenplatte

oder alternativ

Befestigung
 mit großer Bodenplatte

Attachment with
 small floor plate

or alternatively

attachment
 with large base plate

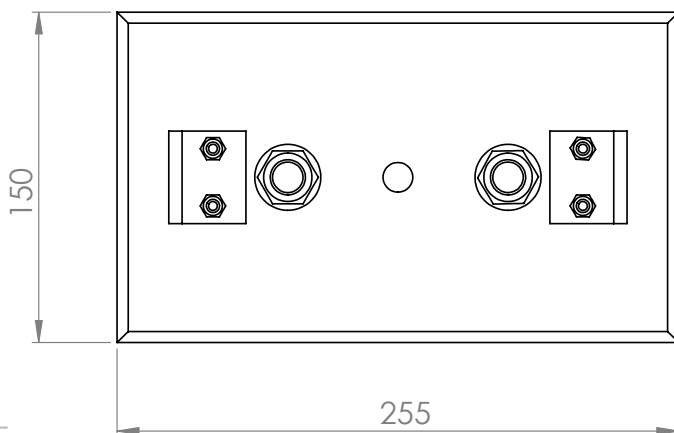
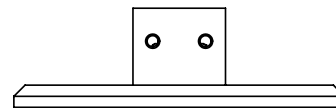

MONTAGEMÖGLICHKEIT 2 - SCHRAUBFUNDAMENT

MOUNTING POSSIBILITY 2 - GROUND SCREW FOUNDATION

Die Befestigung der junosolarleuchte mit einem Krinner Schraubfundament ist nur mit der Bodenplatte (255 mm x 150 mm x 10 mm) möglich!

The attachment of junosolar lamp with a Krinner screw foundation is only possible with the base plate (255 mm x 150 mm x 10 mm)!

KRINNER Schraubfundament / Ground Screw Foundation KSF M 76 x 800-M12

a Länge / Length (+/- 25mm)	815 mm
b Außendurchmesser (Schaft) / Outer diameter (shaft)	76,10 mm
c Innendurchmesser / Inner diameter	70,90 mm
d Gewinde / Thread	M12
e Lochkreisdurchmesser / Bolt circle diameter	116 mm
g Schlüsselweite Flansch / Wrench size flange	120 mm
h Flanschaußendurchmesser / Flange outer diameter	136 mm
i Flanschstärke / Flange thickness	5 mm

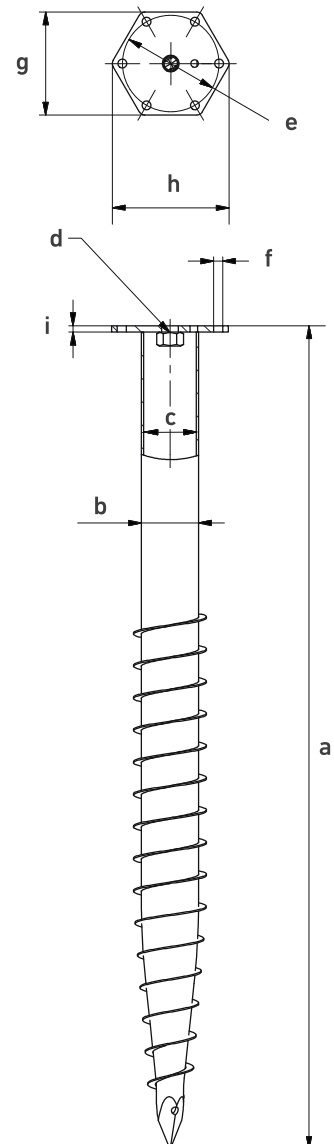

MONTAGEMÖGLICHKEIT 3 - BEFESTIGUNGSKEIL

MOUNTING POSSIBILITY 3 - MOUNTING WEDGE

