

PowerPack 150S

DC power supply for PS2 pump systems

Description

An outdoor rated power supply unit to allow LORENTZ PS2-100 to PS2-150 systems to be powered from an AC (mains voltage) power source. The PowerPack can be used as a continuous supply, in conjunction with PV modules or as a temporary or seasonal supply.

Features

- DC power supply to power LORENTZ solar pump systems from the grid or a generator
- Robust weatherproof housing
- External on / off switch
- Use of MC4 connections to allow quick change over from PV modules to PowerPack
- DC inputs and outputs allow for permanent connection of a solar array
- 1m AC connection cable - NEMA 5-15P (US Plug) or CEE 7/7 (EU Plug)
- Requires a tool to open the housing
- Designed to be used with the LORENTZ PS2-100 to PS2-150 systems



photo may differ from actual product

Ordering and shipping information

- Packed volume: 0.03 m³ (1.03 ft³)
- Packed weight: 3.6 kg (7.1 lbs)
- See next page for item numbers and variants

Approvals and standards

The switch mode power supply has the following approvals

- EN62368-1
- IEC 62103
- IEC 61000-6-2
- IEC 61000-6-4
- AS/NZS 60950-1
- UL62368-1



Technical data / Specifications

	PowerPack 150S
For use with these Pump systems	PS2-100 PS2-150
AC input	100-260 V AC / 50 - 60 Hz
DC output	24 V - 13.4 A
Maximum PV input	50 V DC
PV in connections	2 x MC4
DC out connections	2 x MC4
AC input	IEC C14 female (US or EU cable supplied)
Environmental protection	IP23
Housing material	Polycarbonate

BERNT LORENTZ GmbH

Siebenstuecken 24, 24558 Henstedt-Ulzburg, Germany
Tel. +49 (0) 4193 8806 - 700, www.lorentz.de

All specifications and information are given with good intent, errors are possible and products may be subject to change without notice. Pictures may differ from actual products depending on local market requirements and regulations.

Order information

Item number	Description
19-005290	PowerPack 150S, EU
19-005295	PowerPack 150S, US

Mounting options

- Wall or panel mount using 4 holes with weather protection

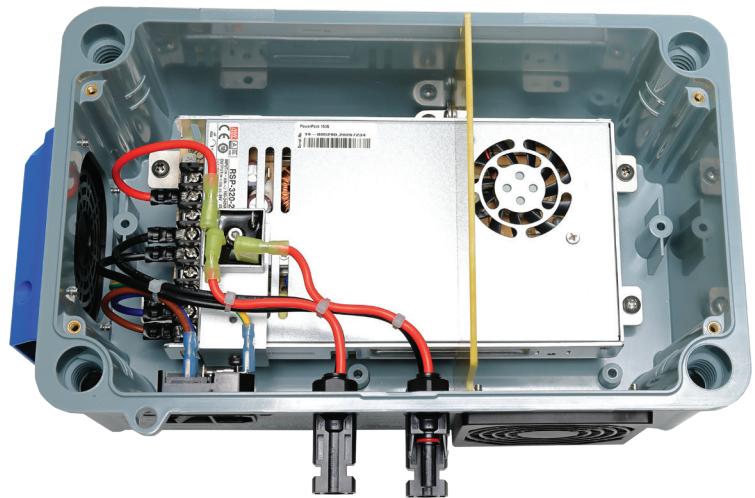

Dimensions and weight

- See drawing for mm measurements
- Max height 220 mm (8.7")
- Max width 325 mm (12.8")
- depth 138 mm (5.4")
- Weight 2.9 kg (6.4 lbs)

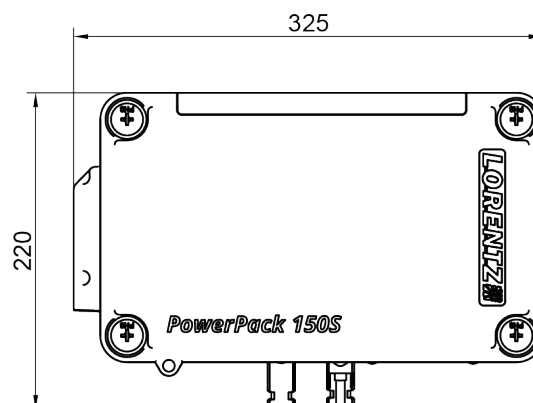
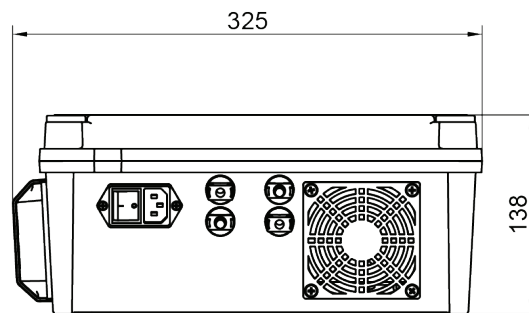

BERNT LORENTZ GmbH

Siebenstuecken 24, 24558 Henstedt-Ulzburg, Germany
 Tel. +49 (0) 4193 8806 - 700, www.lorentz.de

All specifications and information are given with good intent, errors are possible and products may be subject to change without notice.
 Pictures may differ from actual products depending on local market requirements and regulations.